



DSH - DSV

Strainer air separators

Data sheet: DS/FD/0003/EN Ed. 11-2024

Isoil strainers air separators DS protect p.d. meters from damage due to foreign particles and at the same time they also eliminate air/gas in the fluid thus granting high accuracy in measurement.

Working principle

When entering the air separator, the fluid flows through a basket which is made of a filtering mesh. In this way foreign particles in the fluid are held by the strainer and dropped on the bottom so that they can then be removed through the lower drain plug.

Since the designing and assembling of measuring instruments must guarantee a high-level metrological standard, the strainer has been designed to convey eventual air into the gas-separator.

The more air in the system, the more the floating-sphere sinks thus opening the air vent valve .

The opening of the air-separator activates a micro-switch. This in turn closes the automatic valve thus stopping product delivery.

When all the air has been vented out, the rising level of fluid makes the sphere rise up again and the mechanism closes the air-strainer.

Such movement activates the micro-switch again which opens the automatic valve allowing for product delivery.

Features

In order to choose the right filtering mesh consider fluid type.

We suggest:

100 mesh for petrol, 60 mesh for diesel oil e 40 mesh for fuel oils.

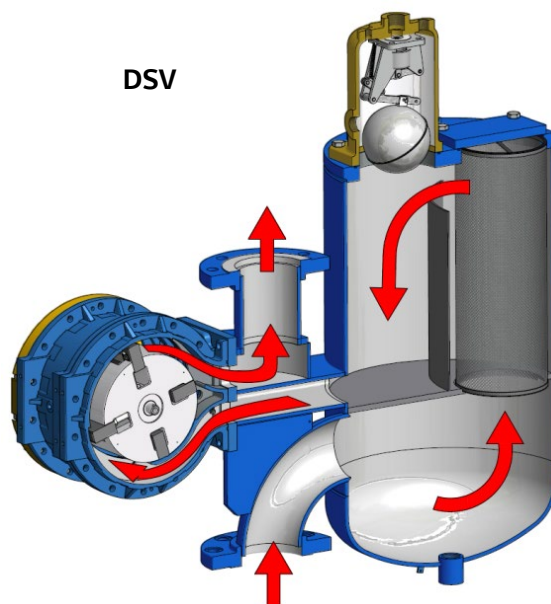
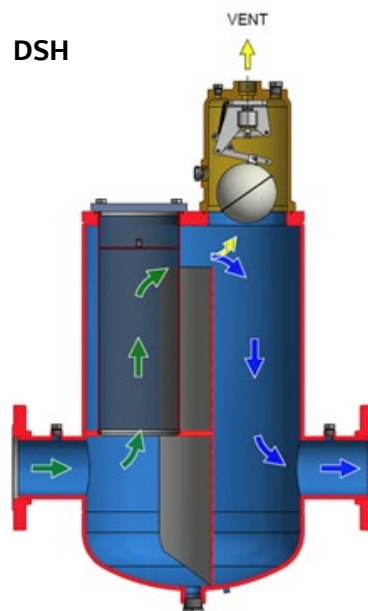

Dimensions DSH

Indicative dimensions in mm

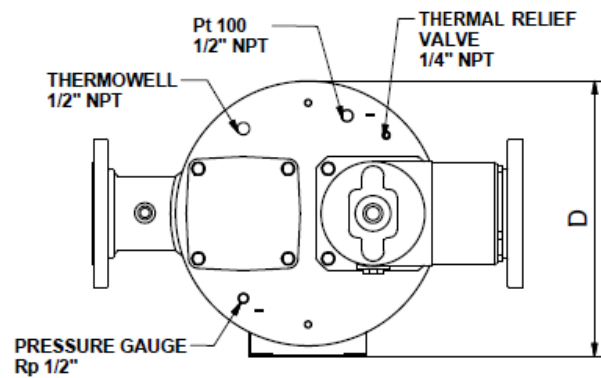
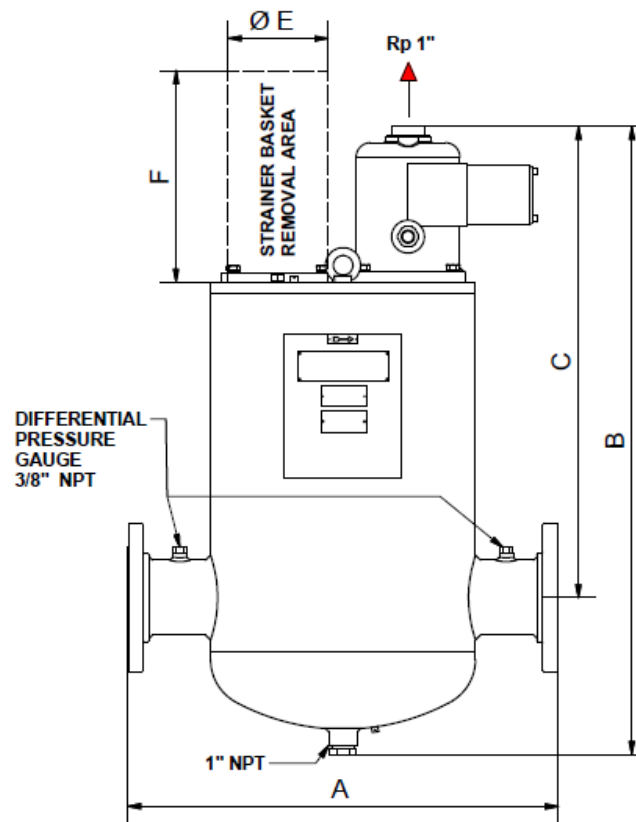

VERSION	A	B	C	D	E	F	X
DSH-80	660	960	710	425	150	407	3" ANSI 150 RF
DSH-100	660	960	710	425	150	407	4" ANSI 150 RF
DSH-150	760	1093	773	530	216	437	6" ANSI 150 RF

Dimensions DSV

Indicative dimensions in mm

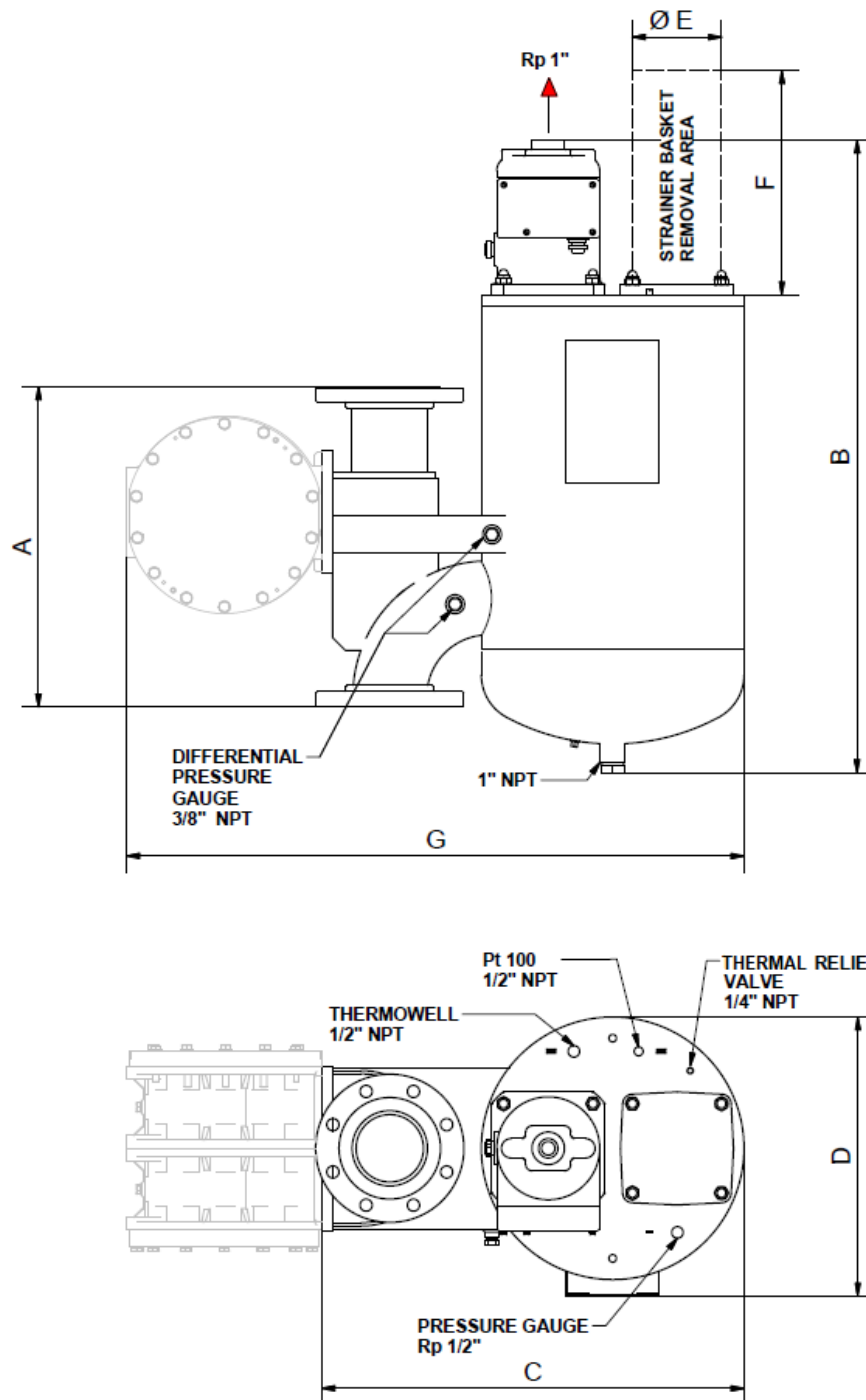

www.isoilmeter.com

VERSION	A	B	C	D	E	F	G	X
DSV 200	385	960	635	420	150	407	960	3" ANSI 150 RF
DSV 400	495	980	650	430	150	407	960	4" ANSI 150 RF
DSV 600	650	1000	775	765	216	437	1150	6" ANSI 150 RF

Accessories

Standard

- * Thermal relief valve
- * Thermowell
- * Micro Ex-d on air vent valve

Upon request

- * Differential pressure gauge with local indicator
- * Differential pressure gauge with ATEX electrical contact
- * Line pressure gauge
- * Ball valve for drain 1"1/4
- * Air vent ball valve 1"
- * Temperature probe Pt 100

Technical data

Maximum operating pressure:	1000 kPa
Maximum differential pressure with dirty strainer:	150 kPa
Standard working temperature:	-10° ÷ 50 °C (non standard temperatures upon request)

Construction

Flanges:	ANSI 150 RF (other flanges upon request)
Strainer body:	Carbon steel (stainless steel upon request)
Strainer basket:	Stainless steel
Cap:	Aluminum
Air vent valve:	Aluminum body Anodized aluminum piston (stainless steel upon request) Stainless steel sphere