



Aviation Meters

series SBM and BM

Data sheet: DS/CO/0012/EN Ed.06-2019

ISOIL aviation p.d. meters sizes 3", 4" and 6" grant high accuracy in measurement ($\pm 0,1\%$) and a repeatability of 0,02%, over a large range of flow rates. This accuracy remains constant during long periods of use.

Measured flow rate can be displayed either on a mechanical or on an electronical counter (e.g. VEGA II or VEGA T).

Applications

- Loading/unloading of tank trucks (refueler), tank wagons and barges
- aircraft refuelling
- pipelines
- calibration of other meters and tanks as Master Meter

Operation

When activated by the pressure inside pipings, liquid flows into the measuring chamber of the p.d. meter thus setting the vanes into motion and, as a consequence, rotating the rotor. The vanes are always in contact with the internal surface of the measuring chamber. Product leakage is therefore avoided and high accuracy is granted.

When using a mechanical register the calibration mechanism allows micrometric adjustment without need to change gears while with electronical counters the meter is equipped with a pulse emitter.

Filtering and air elimination

To assure a measuring accuracy and preserve the meter from damage, the fluid under measurement must be properly filtered and air or gas must be eliminated.

Master Meter

All our meters can be used as master meters by providing them with specific accessories, calibration and configuration.

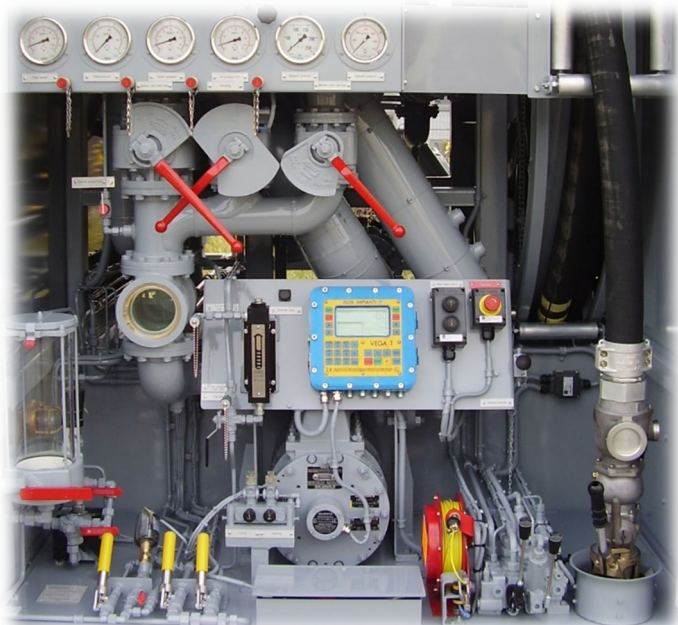

Technical data

- Working pressure: 1000 kPa
- Test pressure: 2100 kPa
- Working temperature: -10°+70°C standard
-30°+70°C low temperature

Compliance

ISOIL aviation meters comply with PED and ATEX Directives.
Evaluation certificate n° GB-1594 of NMO for MID systems.

Calibration certificate

- Meters accuracy curve and linearity are in compliance with JIG1 standard chap. 4.9.1 (into-plane fuelling service)
- Test fluid: water

	SBM75	SBM150	BM 200	BM 400	BM 600
Flow rate (L/min.):	[50 ; 500]	[100 ; 1300]	[120 ; 1400]	[200 ; 2600]	[300 ; 4000]*
Accuracy	± 0.15%	±0.10%	± 0.10%	± 0.10%	± 0.10%
Repeatability	0.04%	0.02%	0.02%	0.02%	0.02%
Manifold and Flanges:	Aluminium	Aluminium	Aluminium	Aluminium	Aluminium
Body:	Aluminium **	Aluminium	Carbon Steel**	Carbon Steel**	Carbon Steel**
Covers:	Carbon Steel**	Carbon Steel**	Carbon Steel**	Carbon Steel**	Carbon Steel**
Rotor:	Aluminium	Aluminium	Aluminium	Aluminium	Aluminium
Vanes:	Xenia	Graphite	Graphite	Graphite	Graphite
Gaskets:	Nitril	Nitril	Nitril	Nitril	Nitril
Ball Bearings:	Stainless Steel	Stainless Steel	Stainless Steel	Stainless Steel	Stainless Steel
Coupling:	Viton lip seal	Viton lip seal	Viton lip seal	Viton lip seal	Viton lip seal
Flanges (std):	square 90 x 90 mm	3" ANSI 150 FF	3" ANSI 150 FF	4" ANSI 150 FF	6" ANSI 150 FF
Flange to flange:	210 mm	330 mm	356 mm	400 mm	400 mm
Readout:	litres	litres	litres	litres x10	litres x10

Note:

* 200-4000 l/min. available upon request. Evaluation certificate n° GB-1594 of NMO for MID systems.

** With corrosion prevention treatment.

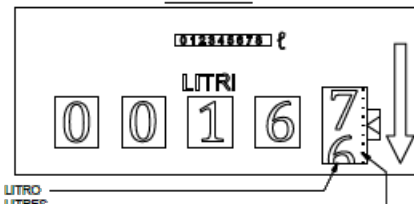
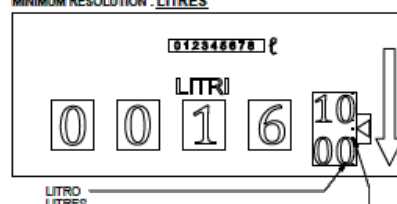
Mechanical counter with single wheel	Mechanical counter with double wheel
<p>RISOLUZIONE MINIMA : DECILITRO MINIMUM RESOLUTION : DECILITRES</p>  <p>Litres</p>	<p>RISOLUZIONE MINIMA : LITRO MINIMUM RESOLUTION : LITRES</p>  <p>Litres x 10</p>

Configuration: meters discharge type and mounting

www.isoilmeter.com

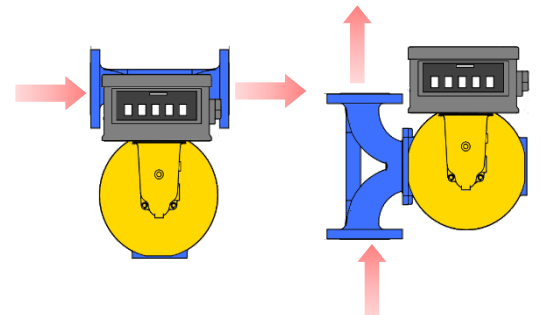
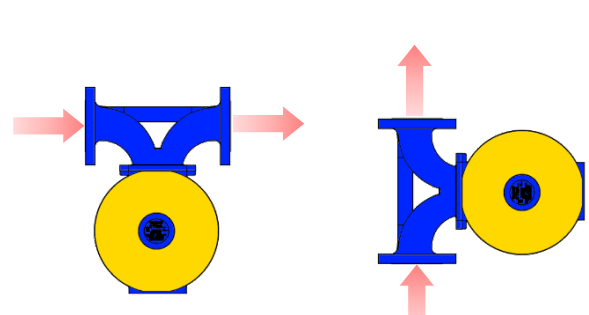
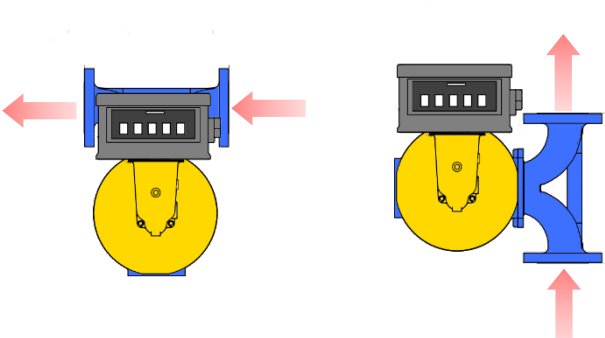
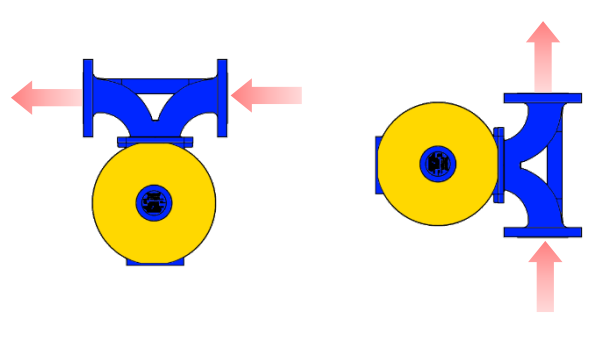
With mechanical counter	With pulse emitter EM6422
 <p>Right discharge Horizontal RH</p> <p>Right discharge Up RU</p>	 <p>Right discharge Horizontal RH</p> <p>Right discharge Up RU</p>
 <p>Left discharge Horizontal LH</p> <p>Left discharge Up LU</p>	 <p>Left discharge Horizontal LH</p> <p>Left discharge Up LU</p>

NOTE: Above configuration is valid for all meters

Dimensions

SBM 75

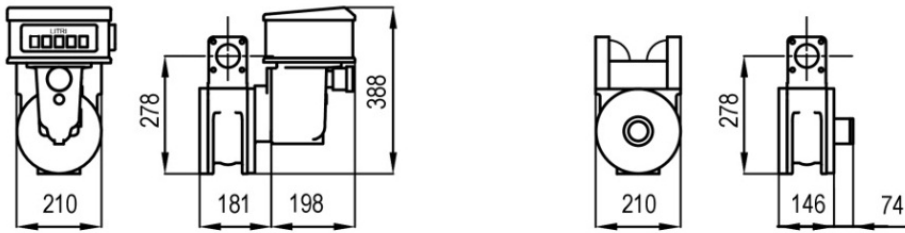

SBM 150

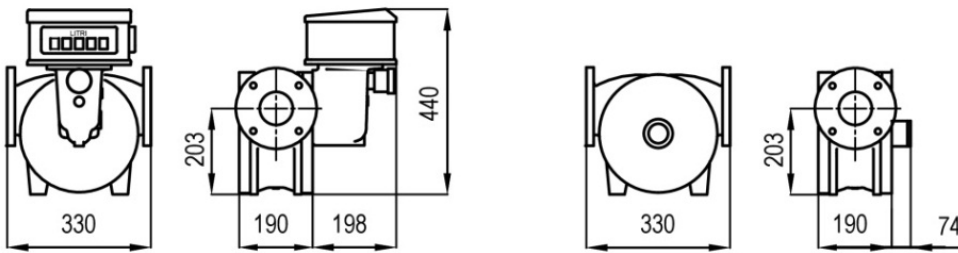

BM 200

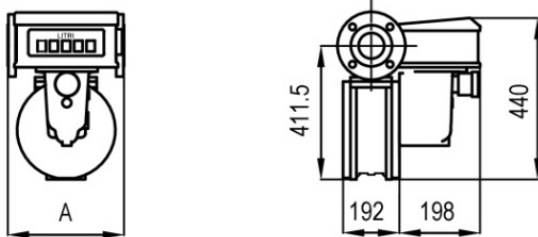

A = 356

BM 400

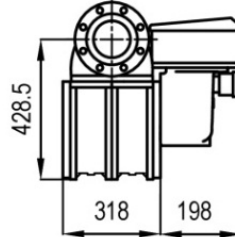

A = 400

BM 600

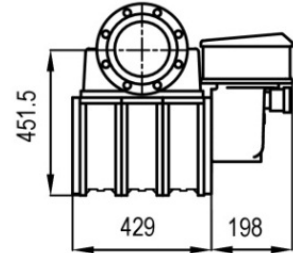

A = 400

BM 200

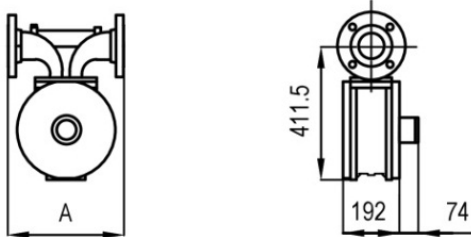

A = 356

BM 400

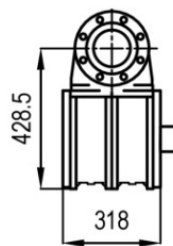

A = 400

BM 600

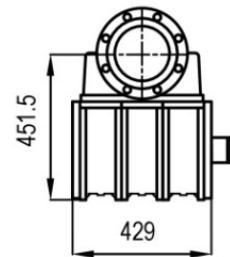

A = 400

www.isoilmeter.com